

Bu Resim MESA OTO ELEKTRİK LTD.ŞTİ'nin malıdır. Şirket Yetkililerinin izni olmaksızın kopya edilemez, üzerinde değişiklik yapılamaz.  
This image MESA AUTO ELECTRIC LTD 's are property. Can not be copied without the consent of the company authorized, any changes can be made.

PARÇA KODU PART CODE	PARÇA ADI PART NAME	s ÖLÇÜSÜ (KALINLIK) s MEASURE (THICKNESS)	Malzeme Material	Kaplama / Coating		
				SN	AG	Nİ
TŞ 2410 DP	1 NO 2.TERMİNAL Ø4.2 =DP=	0.45±0.05	(CuZn30) Pirinç / Brass	-	-	-
TŞ 2410 RP	1 NO 2.TERMİNAL Ø4.2 =RP=	0.45±0.05	(CuZn30) Pirinç / Brass	-	-	-
TŞ 2410 RPK	1 NO 2.TERMİNAL Ø4.2 =RPK=	0.45±0.05	(CuZn30) Pirinç / Brass	+	-	-
TŞ 2410 RÇN	1 NO 2.TERMİNAL Ø4.2 =RÇN=	0.50±0.05	Paslanmaz Sac(430)	-	-	-

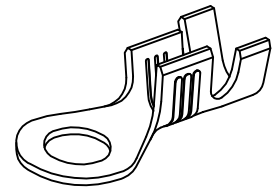
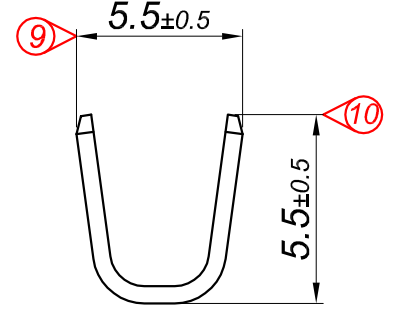
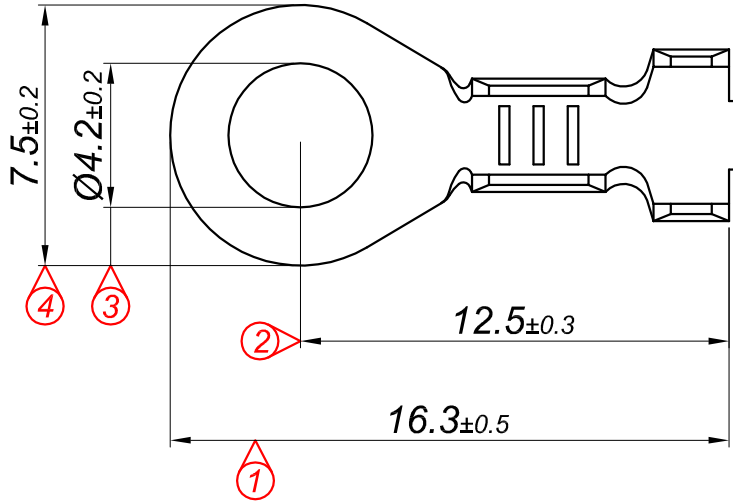
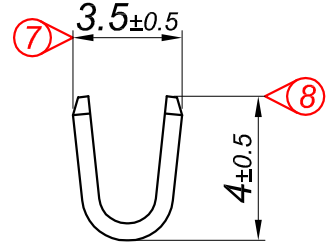
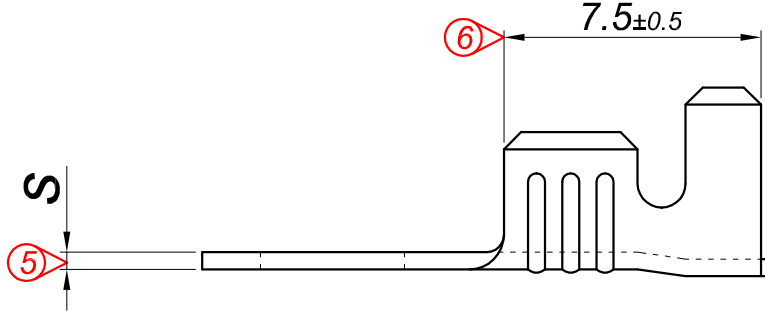

Perspektif  
Perspective

Kalıp çıkış yönü  
Mold output direction

Makara açılım yönü  
Reel opening direction

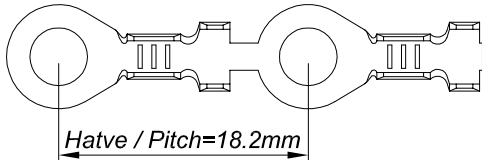

Ölçek  
Scale : 3 / 1

Kablo Kesiti

Wire Section : 0.50 - 1.50 mm<sup>2</sup>

Resim üzerinden ölçü almayınız  
do not measure on drawing

Tarih / Date	19.07.2013	İmza /Signature	Ölçek /Scale		
Çizen / Desing	M.Yağcı		5 / 1	01	ÇİFTLİ KALIP YAPILMIŞTIR.
Onay / Approval	S.Gölcük			No	Değişiklik / Revision
					Tarih/Date



Parça Adı:  
Part Name

1 NO 2.TERMİNAL Ø4.2

Parça Kodu:  
Part Code

TŞ 2410